

*Frozen  
Granita and  
Sorbet  
Machines*

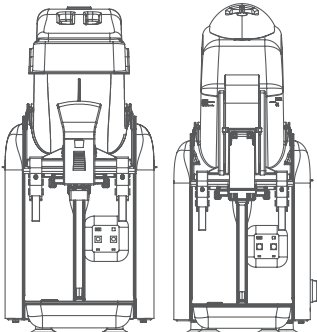

all  
you  
can  
slush

**ELMECCO**  
FROZEN BEVERAGE SOLUTIONS  
• SINCE 1961 •



sorbetto



granita



frozen  
cocktail



frozen  
cream



## Caratteristiche esclusive

Compatta e facile da  
utilizzare

"Total cold",  
refrigerazione dal  
basso

"Senza guarnizione",  
riduce la manutenzione  
preventiva obbligatoria

Gestione elettronica  
per controllo della  
densità e autodiagnosi

Filtro esterno per  
migliorare l'efficienza  
del condensatore



Estremamente flessibile, **Elmeco Big Biz** garantisce alta marginalità con un investimento basso e manutenzione contenuta.

Big Biz è facile da usare e pulire, ha una capacità ridotta di produzione della granita, che rende **semplice e versatile il cambio prodotto**.

Perfetta per la tipica granita italiana, granita di tè, granita di frutta, sorbetti, frozen cocktails e molto altro.

**Scopri le nuove ricette e inventa nuovi gusti.**





sorbetto



granita



milkshake



frozen  
cream



## Caratteristiche esclusive

Erogazione veloce  
grazie al "Total cold"  
con refrigerazione dal  
basso

"Senza guarnizione"  
riduce la  
manutenzione  
preventiva obbligatoria

Gestione elettronica  
per controllo della  
densità e autodiagnosi

Filtro esterno per  
migliorare l'efficienza  
del condensatore



**Elmecc BLarge** è giovane ma molto  
professionale, risultato di molti anni di  
esperienza sul campo.  
Altamente affidabile e compatta,  
mantiene le stesse caratteristiche  
tecniche delle macchine Elmecc e in  
più, con erogazione semplice e veloce,  
ti permette di essere più efficiente.  
Perfetto per granita, dessert frozen, tè e  
yogurt, frozen cocktails e molto altro.







[info@elmeco.com](mailto:info@elmeco.com)  
[www.elmeco.com](http://www.elmeco.com)

#### ITALY HEADQUARTER

*via Circumvallazione Esterna, 12  
80025 Casandrino,  
Napoli, Italy  
Tel +39 081 5055724  
Fax +39 081 5055726*

#### AMERICA DISTRIBUTION CENTER

*652 Griffith Road Suite E  
Charlotte NC  
28217, USA  
Tel: +1 877 435 6326  
Fax +1 704 666 5141*

#### INDIA DISTRIBUTION CENTER

*5th Floor, Sangeet Plaza  
Marol Maroshi Road  
Opp Marol Fire Brigade  
Andheri (East) Mumbai  
India 400 059*